

DISCHARGE AREA EROSION CONTROL DETAIL
N.T.S.

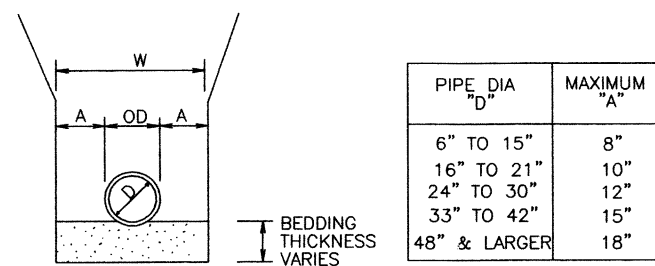

MAXIMUM TRENCH WIDTH "W"
TAKEN AT TOP OF PIPE

NOTE: PROVIDE BEDDING IN ACCORDANCE WITH
THE SPECIFICATIONS.

STANDARD PIPE TRENCH WIDTH
N.T.S.

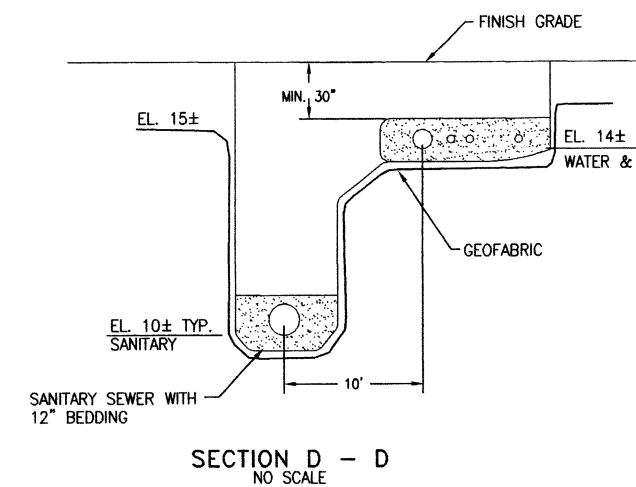
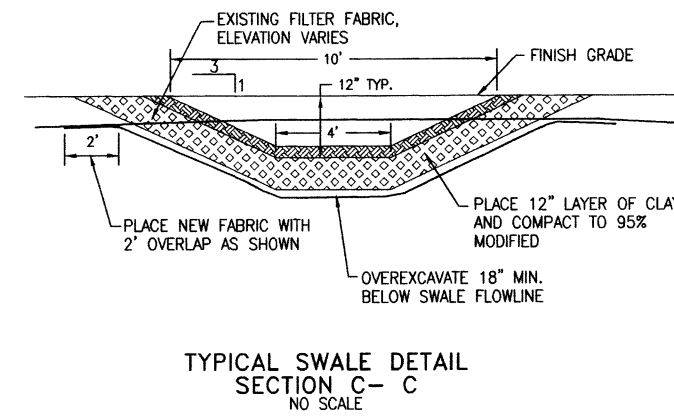
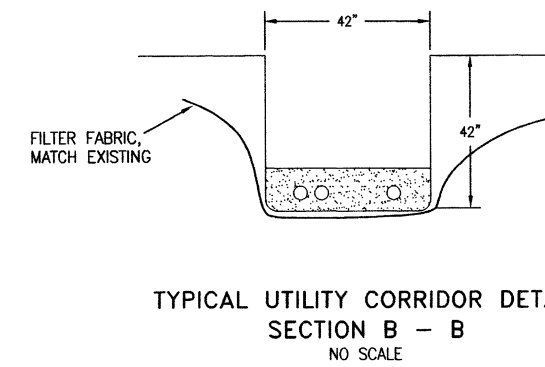
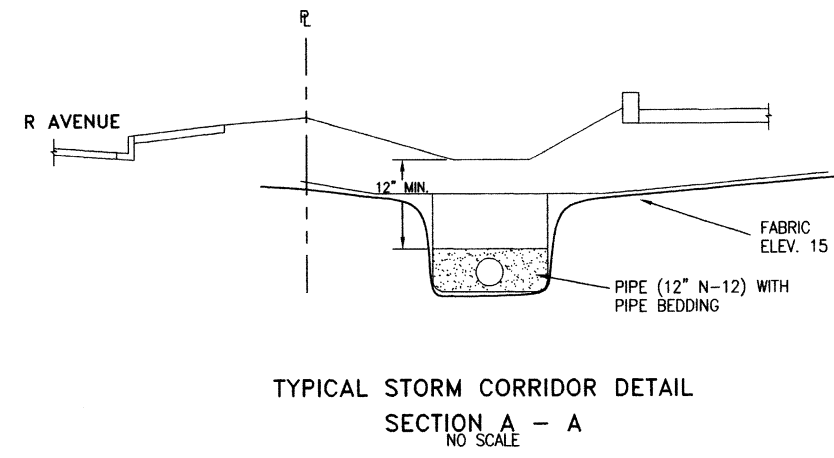

DESIGNED	JAS	SBK	BY
DRAWN	JAS	SBK	BY
CHECKED	JAS	SBK	BY
DATE	1/17/93	DATE	1/17/93

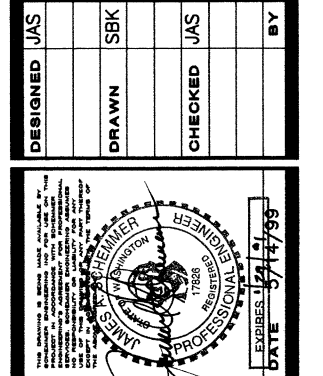

SUN SYSTEMS, INC.
1004 COMMERCIAL AVENUE, SUITE 152
ANACORTES, WA 98221-4183 (360) 293-1960

SUN SYSTEMS, INC.
GRADING NOTES - MISC. DETAILS

JOB NO.	98-012
SHEET	C6
6	OF 11