

AGREEMENT

Lummi Nation School 01-37-903

This Agreement is made and entered into this 1st day of September, 2024, by and between the Northwest Educational Service District, ("NWESD" hereinafter) and the Lummi Nation School District No.903, ("District" hereinafter).

WHEREAS, the NWESD is authorized to provide services to school districts by RCW 28A.310.010;

WHEREAS, the NWESD has formed the Northwest Regional Data Center Cooperative, ("NWRDC" hereinafter);

WHEREAS, the District and NWESD under RCW 28A.320.080, RCW 28A.310.200, and RCW 39.34.080 are empowered to enter into agreements for Interlocal agreements and cooperative service programs; and,

WHEREAS, the District desires to enter into a cooperative service agreement with the NWESD;

IT IS HEREBY AGREED that the NWESD shall receive funds from the District and shall expend such funds for the purpose of providing information systems services through the NWRDC and the Washington Schools Information Processing Cooperative, ("WSIPC" hereinafter) in accordance with the terms and conditions set forth herein:

1. GENERAL TERM OF THE AGREEMENT

The term of the Agreement is September 1, 2024 through August 31, 2025, upon receipt of full annual payment by August 15th, 2024. Thereafter, the terms of the Agreement will automatically renew from September 1st through August 31st of each successive year.

This term shall continue unless NWESD or District gives written notice to the other party to terminate the Agreement. This notice must be provided to District or NWESD, respectively, by March 15th of the same year termination is desired, at which time District agrees to continue paying Cooperative fees until August 31st of the same year.

NWESD, through NWRDC, will invoice District for the full annual payment for the following year's services by July 15th of the prior year.

Should District fail to provide full payment by August 15th, the Agreement shall terminate and all service will be discontinued, effective September 1st. NWRDC will make every reasonable effort to provide its raw data to District upon its written request.

2. MEMBERSHIP IN NORTHWEST REGIONAL DATA CENTER

District shall become a full member of NWRDC effective September 1, 2024. Membership shall entitle District to nominate candidates and vote for representatives on the NWRDC Executive Committee. NWRDC is a part of and functions through NWESD.

3. INFORMATION SYSTEM SERVICES

During the term of this Agreement, NWESD agrees, through NWRDC, to provide to District information system services as set forth in the Appendix A, which outlines the software, service levels, roles and responsibilities of NWRDC to District in support of student, business and personnel related software packages offered by WSIPC including software support, amount and method of customer support, performance levels, and availability of staff, of this Agreement.

4. PROGRAM DEVELOPMENT

NWESD agrees that priority in the development of new applications services by WSIPC shall be in accordance with the expressed direction of the WSIPC Board of Directors operating under their bylaws.

5. COST TO THE DISTRICT

During each year of the term, the WSIPC fee will be incorporated into the total fee collected by NWESD. The WSIPC fee is established by the WSIPC Board of Directors and the NWRDC fee is established by the NWRDC Executive Committee.

The annual per student FTE fee for services provided under this Agreement will be determined pursuant to the Appendix B fee schedule. Districts will be notified of subsequent years per student FTE fee updates by March 1st of each year.

The student FTE component of the fee calculation is variable and will be based on the actual annual average student FTE count for the prior fiscal year as reported by OSPI on the 1191ED Apportionment report. The per student fee value is based on the level of service selected by the District.

The district can calculate the total cost by multiplying the per student fee by the annual average student FTE. This cost includes amounts for sales use or other similar taxes related to the services provided herein. One twelfth of the annual cost will be invoiced for the first ten months of the Agreement. A final adjustment shall be made to the actual average annual FTE for the current year on the July and August payments.

6. RIGHTS TO PARTICIPATE IN JOINT COOPERATIVE

As authorized by RCW 28A.320.080 (3) and RCW 28A.310.180 (3) (currently existing or hereinafter amended), group purchasing and/or bidding for data processing equipment and/or services, or related equipment and/or services, may be part of the activities of the ESD cooperatives. Members of these cooperatives may, at their own option, participate in the bidding/purchasing role of WSIPC, but will not be required to do so for any particular item(s).

7. CONFIDENTIALITY

All materials furnished to WSIPC and NWRDC by District pursuant to this Agreement, shall remain the property of District and shall not be disclosed to third parties except by written consent of District. These materials include, but are not limited to, source data, computer files, reports, listings and computer programs.

NWRDC and WSIPC acknowledge that performance of Services under this Agreement may involve access to confidential information including, personally identifiable information, student records, protected health information, or individual financial information. WSIPC and NWRDC will comply with State or Federal law/rules restricting the use and disclosure of such information, (reference Family Educational Rights and Privacy Act (20 U.S.C. § 1232g)).

8. ACCESS TO PUBLIC RECORDS

No records of District shall be made available for public inspection or copying by NWRDC, NWESD, or WSIPC without express written authorization of District. Requests pursuant to RCW 42.17 for inspection or copying of public records of District, held or maintained by NWRDC shall be referred to District.

9. RIGHTS IN COMPUTER SOFTWARE

During the term of this Agreement, District agrees that it shall safeguard all Skyward, Inc., NWRDC, and WSIPC proprietary materials as set forth under "Grant and Limitations" in the WSIPC Software and Systems: Services and Support portion of Appendix A.

10. PERFORMANCE AND BONDING

NWESD shall not be liable for inadequate services or errors caused by inaccurate or inadequate input data, programs or other software furnished by District.

11. DISPUTES

Any dispute, claim or grievance arising out of or relating to the interpretation or application of this Agreement shall be resolved by a three-member committee. The representatives shall be selected by NWESD and District, each selecting one representative. Thereafter, NWESD's representative and District's representative shall select an impartial third party who shall serve as the third member of the committee. This dispute resolution committee

shall be guided and limited by the terms and conditions expressly delineated in this Agreement.

12. TERMINATION FOR BREACH

If either party fails to comply with the terms and conditions of this Agreement, the other party upon thirty (30) days prior written notice to the breaching party may terminate this Agreement.

13. INTERLOCAL AGREEMENT

This Agreement provides authority in addition to those vested by RCW 28A.310.200 and RCW 28A.320.080, is be deemed to be in satisfaction of the provisions of RCW 39.34, and is deemed a contract pursuant to RCW 39.34.080

14. CRIMES AGAINST CHILDREN

In accordance with RCW 28A.400.330, employees, agents, and contractors of NWESD are prohibited from working at a school if they have or may have contact with children at a public school during the course of their employment and have pleaded guilty to or been convicted of the crimes identified in RCW 28A.400.322. Any failure to comply with this section shall be grounds for District immediately terminating the Agreement.

15. INDEMNITY

NWESD shall defend, indemnify, and hold harmless District in full for any and all claims against District or its employees, officials, or contractors which arise from the acts or omissions of NWESD and its employees, officials, and contractors in the provision of services under this Agreement. District shall defend, indemnify, and hold harmless NWESD in full for any and all claims against NWESD or its employees, officials, or contractors which arise from the acts of omissions of District and its employees, officials, and contractors in the provision of services under this Agreement.

16. ASSIGNMENT

This Agreement may not be assigned by either party without written consent of the parties.

17. WAIVER AND SEVERABILITY

No provision of this Agreement, or the right to receive reasonable performance of any act called for by its terms, shall be deemed waived of a breach thereof as to a particular transaction or occurrence.

If any term or condition of this Agreement or application thereof to any person or circumstance is held invalid, such invalidity shall not affect other terms, conditions or applications of the Agreement which can be given effect without the invalid term, condition or application; to this end the terms and conditions of this Agreement are declared severable.

18. ENTIRE AGREEMENT

The parties acknowledge that they have read and understand this Agreement, including any supplements or attachments hereto, and do agree thereto in every particular. The parties further agree that this Agreement, together with all appendices, constitutes the entire Agreement between the parties and supersedes all communications, written or oral, heretofore related to the subject matter of this Agreement. This Agreement may be modified or amended, in writing, with the mutual consent of the parties. With the signatures below, the parties indicate that they have the legal authority to obligate their respective agency to the terms and conditions contained herein.

Lummi Nation School School District No. 903 elects to contract for:

Full Services

Board approval date: _____

OR

Resolution number _____ and date _____, of board delegation of authority to sign interlocal agreements.

DocuSigned by:
Dr. Lexie Tom 8/14/2024
65A29BD9B3FF4EA...
(Superintendent Signature) (Date)

Lexie Tom

Printed Name

whatcom _____, Washington
(County)

DocuSigned by:
Dr. Ismael Vivanco 8/14/2024
0EE5F61D5CAE402...
(Date)

Dr. Ismael Vivanco, Superintendent
Northwest Educational Service District 189
Skagit County, Washington

NWESD Internal Approvals:

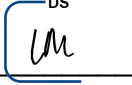
Fiscal: 

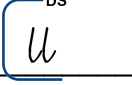
Program Manager: 

Appendix A

Software and Systems - Services and Support

NWRDC Services

The following services are currently available to member districts. Every member of NWRDC may contract for Fiscal/HR Services (Business), Student Services or Full Services (both).

Service Requests

To request support during Normal Business Hours, the following points of contact will be used:

Business Support Team

425-349-6560

nwrdcfiscalsupport@nwrdc.net

<https://www.nwrdc.net/business-team/>

Student Support Team

425-349-6570

nwrdcstu@nwrdc.net

<https://www.nwrdc.net/student-team/>

Print Operations Team

425-349-6666

croom@nwrdc.net

<https://www.nwrdc.net/operations-team/>

Response Times

NWRDC monitors the phone/e-mail support queues during normal business hours to ensure timely responses. At any time an issue is determined critical, the client will be notified within one hour of its status and every two hours thereafter.

A critical incident meets any of the following conditions:

- Productivity has stopped
- A staff member or agency cannot continue work
- Data is corrupt
- Financial controls are impaired
- System security has been compromised

Application Support Services

NWRDC services are available to employees of the District for the application under contract. Services may include but are not limited to telephone support, training, user documentation materials and consulting in conjunction with the utilization of the WSIPC provided software. When the District contracts with outside consultants, it is recommended that these consultants attend relevant training.

Data Transportation

NWRDC assumes responsibility and cost to deliver computer output via United Parcel Service to a single designated drop-off location within the District. Districts requesting delivery to multiple drop-off points will be billed for this added service. The District may elect to pick up their output at the NWRDC Data Services. Data shipped from the District to NWRDC is the financial responsibility of the District.

Paper and Special Forms

NWRDC reserves the right to bill the district for paper usage beyond approved levels as determined by the NWRDC Executive Committee. Additional fees will be levied for anything beyond that limit. Paper and special forms used in the district on terminals, personal computers and other office machines are provided by the district.

Terminal Communications

District assumes responsibility for the costs and support of hardware, telecommunication software, and telecommunication connection costs to the access points established by NWRDC. NWRDC provides Active Directory account management for member districts, including Remote Desktop Services (RDS) support.

Additional Services

Districts may contract with the NWRDC for special projects, which are not covered in the above services or included in the membership agreement. Such services shall be provided under the policy and rates adopted by NWESD and based on the availability of staff. For more information visit our website at

Print Shop: <https://www.nwrdc.net/operations-team/print-shop/>

Contract Business Services: <https://www.nwrdc.net/business-team/contract-business-services/>.

WSIPC Services

SYSTEM AVAILABILITY

Normal: Monday – Friday; 6:00 AM – 6:00 PM

Defined as primary school district work hours during which no elective downtime is done by WSIPC.

Evening/Weekend/WSIPC Holiday: Monday-Friday; 6:00 PM – 11:00 PM;

Weekends: 6:00 AM – 11:00 PM

Defined as hours during which elective downtime can be scheduled with one week's notice. End-users can access the application. Individual components of a redundant group may be unavailable. Approval is required by the NWRDC Director and WSIPC Operations department heads. Advance communication will be sent to the NWRDC Director and WSIPC Operations departments. At the conclusion of downtime, communication will be sent to this same group.

Late Night: Monday – Sunday; 11:00 PM – 6:00 AM

Defined as hours during which backups, system reboots and maintenance can occur. Elective downtime may be scheduled with same-day notice. Services may be unavailable. Advance communication will be sent to the NWRDC Director and WSIPC Operations departments. At the conclusion of downtime, communication will be sent to this same group.

SMS 2.0 Release Weekend: Saturday; 12:00AM – 9:00 PM

Defined as three time yearly period during which SMS 2.0 application software, hardware and operating system maintenance is performed. Expect services to be unavailable. Approval required by the Data Center Director(s) and WSIPC Operations department heads. Advance communication will be sent to the Data Center Director(s) and WSIPC Operations departments. At the conclusion of downtime, communication will be sent to all data centers and WSIPC Operations departments. The approved down time schedule will be communicated regularly throughout the year to reduce the number of surprises to Cooperative members.

Qmlativ Releases

WSIPC Qmlativ software update releases are an automated function. WSIPC has designated the timeframe of 11 PM to 5 AM for these functions. The frequency of releases is biweekly, and patches when needed. Timing can change at the direction of Skyward.

Emergency Downtime

Emergency downtime can be performed for degradation of hardware or software components for which either of the following is true:

- The software or hardware is part of the failover system for a mission-critical system.
- The software or hardware is a single point of failure for a mission critical system.

Emergency downtime can be requested between the hours of 6:00 PM and 6:00 AM with same-day notice or an agreed upon elected time with same-day notice. Advanced communication will be sent to the Data Center Director(s) and WSIPC Operations departments. At the conclusion of downtime, communication will be sent to this same group.

Service Continuity

In the event of complete failure of the SMS 2.0 centralized hosting provided by the Cooperative a failover system is in place for limited mission-critical access to core software and data systems. Backup or redundant capacity exists for database, servers and network. This failover capacity will only be used for dramatic and sudden system failure of the primary hosting center, but will not be utilized during normal, routine, or scheduled down time. WSIPC also has a redundant network link to provide connectivity to SMS 2.0 in the event of an outage with the primary K-20 circuit. Virtual Router Redundancy Protocol (VRRP) communicates to two routers, K-20s 10GB router and the Comcast router connected to a provisioned switch.

SOFTWARE

Delivery

WSIPC, in conjunction with NWRDC, will ensure the software WSIPC provides complies with state reporting, budgeting, and personnel retirement requirements. WSIPC will install the Software either at a site hosted or purchased by WSIPC or at a locally designated site. All software modules supported under this Agreement is documented in Addendum I and posted on our website: <https://www.nwrdc.net/about-us/services/>.

Warranty

WSIPC warrants that upon delivery by WSIPC: (a) the Software will perform substantially in accordance with its written specifications established by WSIPC; and (b) the Software does not infringe any U.S. patent or copyright. WSIPC does not warrant that the Software is free from bugs, errors, or omissions. The exclusive warranties set forth in this paragraph apply only to the latest release of such items of Software incorporating all corrections, updates, enhancements, and modifications made available by WSIPC.

Performance Remedy

As Licensee's exclusive remedy and WSIPC's entire liability, if any Software subject to the warranty set forth in Addendum I Cooperative Supported Products listed on our website at <https://www.nwrdc.net/about-us/services/>, fails to comply with the warranty set forth WSIPC will use reasonable efforts to correct the noncompliance (e.g., by furnishing an update, new release, enhancement, or modification of the noncomplying Software); provided that (i) Licensee notifies WSIPC of the noncompliance and (ii) WSIPC is able to reproduce the noncompliance on the hardware for which the Software was designed. If after the expenditure of such reasonable efforts and the expiration of a reasonable time period WSIPC is unable to

correct any such noncompliance, WSIPC will refund to Licensee a pro rata portion of the license fee paid by Licensee during the then current Year for that portion of the Software found to be noncomplying. Such refund will be in full satisfaction of all claims of Licensee relating to such noncompliance.

Grant & Limitations

WSIPC grants through NWRDC a nontransferable, nonexclusive license during the Term to use the software and documentation for District data operations. The District will not disclose or make available any software or documentation associated with this Agreement to any parties or persons not using the same on behalf of the District. Nor will the District change, modify or alter any software without prior written permission from WSIPC through NWRDC. In short, the District agrees that it shall safeguard all proprietary materials being serviced by WSIPC and shall not infringe on or violate any vendor license agreements WSIPC has entered into on their behalf. If a vendor working on behalf of the District needs to access data in a way not provisioned through the software, the vendor will be required to sign a Non-Disclosure Agreement with WSIPC.

Software Updates

WSIPC agrees to keep current with software licensed from Skyward and will install new versions on a timeline that will be communicated to ISC's and School Districts.

School District Workstations

Configuration requirements for devices and their software that school district personnel use to access WSIPC's software modules can be found on our website:

<https://www.nwrdc.net/technology-team/>.

Reporting

WSIPC will provide reports that impact a majority of the school districts in the Cooperative, are supported by the software design, and which are defined and mandated by legislative statute or an official state agency (e.g. OSPI) where clearly defined reporting specifications are provided. Such reports are formal, often required for compliance with state education laws or regulations, and serve official administrative, monitoring, or policy-making purposes. WSIPC will work with state agencies and affected partner organizations to gather requirements for the report. WSIPC and/or NWRDC will inform Districts of any mandated changes.

Custom Reports and Imports

Any agency may request the creation of a custom report, import, or export. Such services may incur an additional fee. If an agency chooses to proceed with a request, the request will be considered, requirements will be gathered, and a quote for the work will be provided.

WSIPC SaaS Modules

WSIPC may provide additional software to enhance or supplement WSIPC's standard offerings. The costs for these optional offerings are in addition to the normal FTE fee. Fees for optional

SaaS modules are also variable and follow the same general terms of this Agreement. Refer to [Addendum I](#) for the current listing of SaaS software offerings.

WSIPC Purchasing Program

The WSIPC Purchasing Program connects education and public agencies to a network of technology partners, leveraging the power of the WSIPC Cooperative to provide competitively bid goods and services at a reasonable cost.

Each vendor who becomes a part of the WSIPC Purchasing Program has been awarded a bid contract through an official competitively bid RFP process in compliance with Washington State Procurement RCWs.

For more information and a current list of vendors, visit the WSIPC website:
<https://www.wsipc.org/purchasing>

Appendix B

NWRDC FTE Rates

2024 - 2025

	NWRDC Software Support Services	WSIPC Software Licensing	Total FTE Rate
Fiscal Only	\$14.63	\$22.20	\$36.83
Student Only	\$15.56	\$14.94	\$30.50
Full Service	\$26.32	\$22.20	\$48.52

Form **W-9**
(Rev. March 2024)
Department of the Treasury
Internal Revenue Service

Request for Taxpayer Identification Number and Certification

Go to www.irs.gov/FormW9 for instructions and the latest information.

Give form to the
requester. Do not
send to the IRS.

Before you begin. For guidance related to the purpose of Form W-9, see *Purpose of Form*, below.

1 Name of entity/individual. An entry is required. (For a sole proprietor or disregarded entity, enter the owner's name on line 1, and enter the business/disregarded entity's name on line 2.)

Northwest Educational Service District 189

2 Business name/disregarded entity name, if different from above.

3a Check the appropriate box for federal tax classification of the entity/individual whose name is entered on line 1. Check only **one** of the following seven boxes.

Individual/sole proprietor C corporation S corporation Partnership Trust/estate

LLC. Enter the tax classification (C = C corporation, S = S corporation, P = Partnership) _____

Note: Check the "LLC" box above and, in the entry space, enter the appropriate code (C, S, or P) for the tax classification of the LLC, unless it is a disregarded entity. A disregarded entity should instead check the appropriate box for the tax classification of its owner.

Other (see instructions) **Government**

4 Exemptions (codes apply only to certain entities, not individuals; see instructions on page 3):

Exempt payee code (if any) _____

Exemption from Foreign Account Tax Compliance Act (FATCA) reporting code (if any) _____

(Applies to accounts maintained outside the United States.)

3b If on line 3a you checked "Partnership" or "Trust/estate," or checked "LLC" and entered "P" as its tax classification, and you are providing this form to a partnership, trust, or estate in which you have an ownership interest, check this box if you have any foreign partners, owners, or beneficiaries. See instructions _____

5 Address (number, street, and apt. or suite no.). See instructions. Requester's name and address (optional)

1601 R Ave

6 City, state, and ZIP code

Anacortes, WA 98221

7 List account number(s) here (optional)

Part I Taxpayer Identification Number (TIN)

Enter your TIN in the appropriate box. The TIN provided must match the name given on line 1 to avoid backup withholding. For individuals, this is generally your social security number (SSN). However, for a resident alien, sole proprietor, or disregarded entity, see the instructions for Part I, later. For other entities, it is your employer identification number (EIN). If you do not have a number, see *How to get a TIN*, later.

Note: If the account is in more than one name, see the instructions for line 1. See also *What Name and Number To Give the Requester* for guidelines on whose number to enter.

Social security number

			-				-				
--	--	--	---	--	--	--	---	--	--	--	--

or

Employer identification number

9	1	-	0	8	6	8	0	5	6
---	---	---	---	---	---	---	---	---	---

Part II Certification

Under penalties of perjury, I certify that:

- The number shown on this form is my correct taxpayer identification number (or I am waiting for a number to be issued to me); and
- I am not subject to backup withholding because (a) I am exempt from backup withholding, or (b) I have not been notified by the Internal Revenue Service (IRS) that I am subject to backup withholding as a result of a failure to report all interest or dividends, or (c) the IRS has notified me that I am no longer subject to backup withholding; and
- I am a U.S. citizen or other U.S. person (defined below); and
- The FATCA code(s) entered on this form (if any) indicating that I am exempt from FATCA reporting is correct.

Certification instructions. You must cross out item 2 above if you have been notified by the IRS that you are currently subject to backup withholding because you have failed to report all interest and dividends on your tax return. For real estate transactions, item 2 does not apply. For mortgage interest paid, acquisition or abandonment of secured property, cancellation of debt, contributions to an individual retirement arrangement (IRA), and, generally, payments other than interest and dividends, you are not required to sign the certification, but you must provide your correct TIN. See the instructions for Part II, later.

Sign Here	Signature of U.S. person		Date	5/15/2024
------------------	--------------------------	---	------	-----------

General Instructions

Section references are to the Internal Revenue Code unless otherwise noted.

Future developments. For the latest information about developments related to Form W-9 and its instructions, such as legislation enacted after they were published, go to www.irs.gov/FormW9.

What's New

Line 3a has been modified to clarify how a disregarded entity completes this line. An LLC that is a disregarded entity should check the appropriate box for the tax classification of its owner. Otherwise, it should check the "LLC" box and enter its appropriate tax classification.

New line 3b has been added to this form. A flow-through entity is required to complete this line to indicate that it has direct or indirect foreign partners, owners, or beneficiaries when it provides the Form W-9 to another flow-through entity in which it has an ownership interest. This change is intended to provide a flow-through entity with information regarding the status of its indirect foreign partners, owners, or beneficiaries, so that it can satisfy any applicable reporting requirements. For example, a partnership that has any indirect foreign partners may be required to complete Schedules K-2 and K-3. See the Partnership Instructions for Schedules K-2 and K-3 (Form 1065).

Purpose of Form

An individual or entity (Form W-9 requester) who is required to file an information return with the IRS is giving you this form because they



Evidence of Coverage – General Certificate

This Evidence of Coverage is issued as a matter of information only and confers no rights upon the evidence holder. This evidence does not amend, extend, or alter the coverage afforded by the coverage agreement below and is subject to all the terms, exclusions and conditions of such coverage agreement. As a statutorily authorized and self-funded public entity interlocal cooperative among school and educational service districts, there is no insurance policy involved. Because WSRMP is not an insurance company, we cannot grant “additional insured” status (WAC 200-100-02005 and 02007). This is to certify that the coverage listed below has been issued to the named Covered Member for the period indicated.

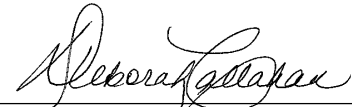
Coverage Afforded By:	Covered Member:
Washington Schools Risk Management Pool PO Box 88700 Tukwila, WA 98138-2700	Northwest ESD 189 1601 R Ave Anacortes, WA 98221 Member #: 29189
Coverage Agreement #:	COV 2023-2024
Coverage Period:	September 1, 2023 through August 31, 2024
Effective Date of Evidence of Coverage:	September 1, 2023
Expiration Date of Evidence of Coverage:	August 31, 2024
Limits Available General Liability Per Occurrence:	\$1,000,000
Limits Available Property:	\$1,000,000
Limits Available Auto Liability:	\$1,000,000
Description of Operations/Locations/Vehicle:	
Activities under the direct supervision of personnel as respects coverage period September 1, 2023 through August 31, 2024.	
Evidence of Coverage Holder:	Issue Date: September 1, 2023
To Whom It May Concern	 _____ Authorized Signature

Cancellation: Should the above described coverage agreement be cancelled before the expiration date, WSRMP will send 30 days written notice to the evidence of coverage holder named above.